

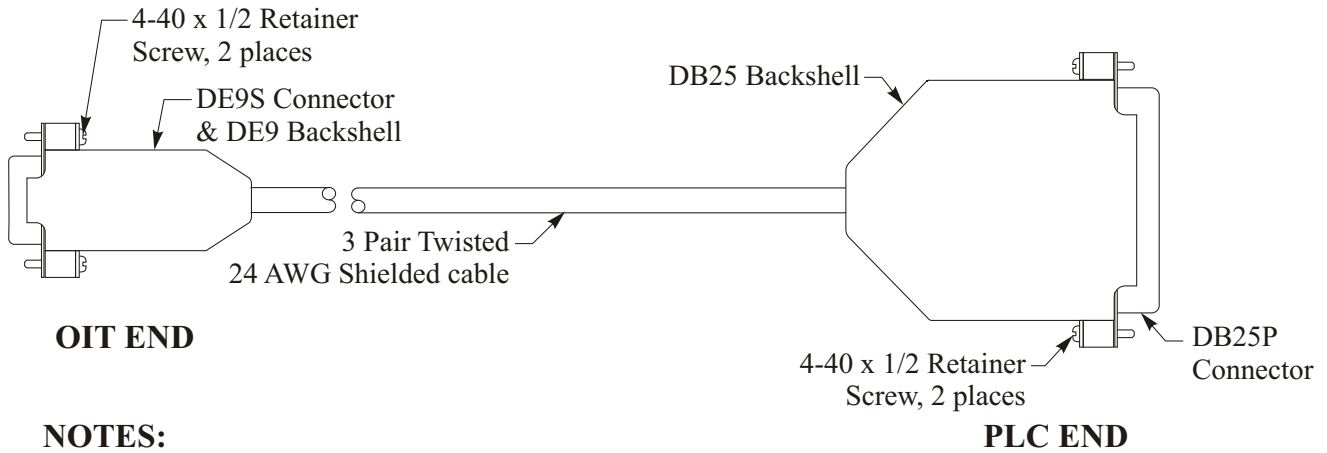

Controller Model: **GE Fanuc 90-30 CMM311 Port 2**
 Maple OIT Model: **Gold Series**
 Communication Type: **RS-485 with DB25 connector at PLC**

Use the wiring diagram and illustration to assemble a communication cable for use with a GE Fanuc 90-30 PLC (CMM311 Port 2).



NOTES:

- 1 Install heatshrink on shield (bare wire) to avoid shorting to components.

