

CABLE ASSEMBLY INSTRUCTION

Maple Model(s)

HMI5000 Series (COM1)
HMI600 Series (COM1)

PLC or Controller

GE Intelligent Platforms
Series 90, VersaMax, and
PAC Systems RX3i

Communication Type

RS-485 with DA15
Connector at PLC



Summary

Use the wiring diagram and illustration to assemble a communication cable for use with a GE Intelligent Platforms Series 90, VersaMax, or PAC Systems RX3i PLC. This cable is for communication through a SNP-X port connection.

Drawing and Schematic

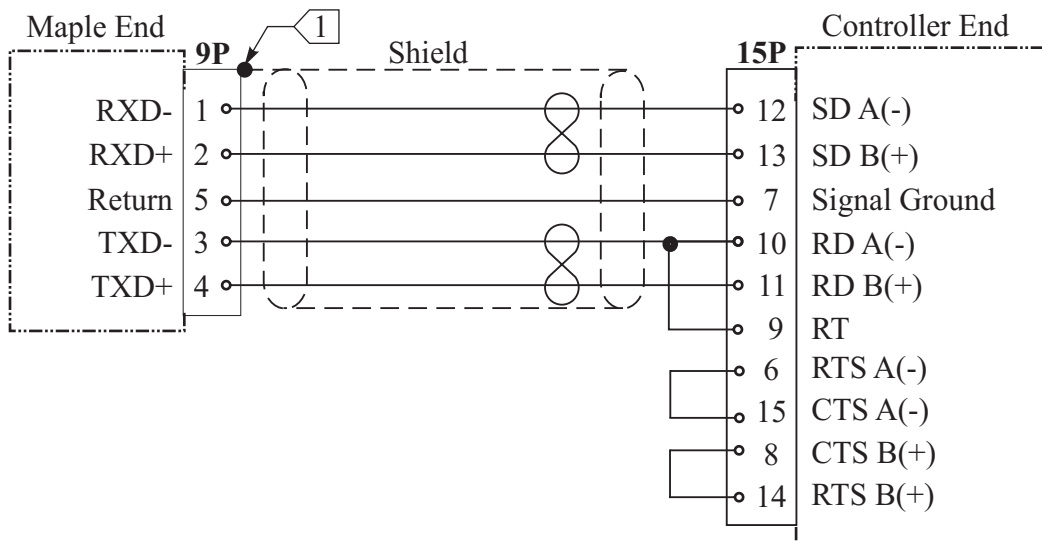
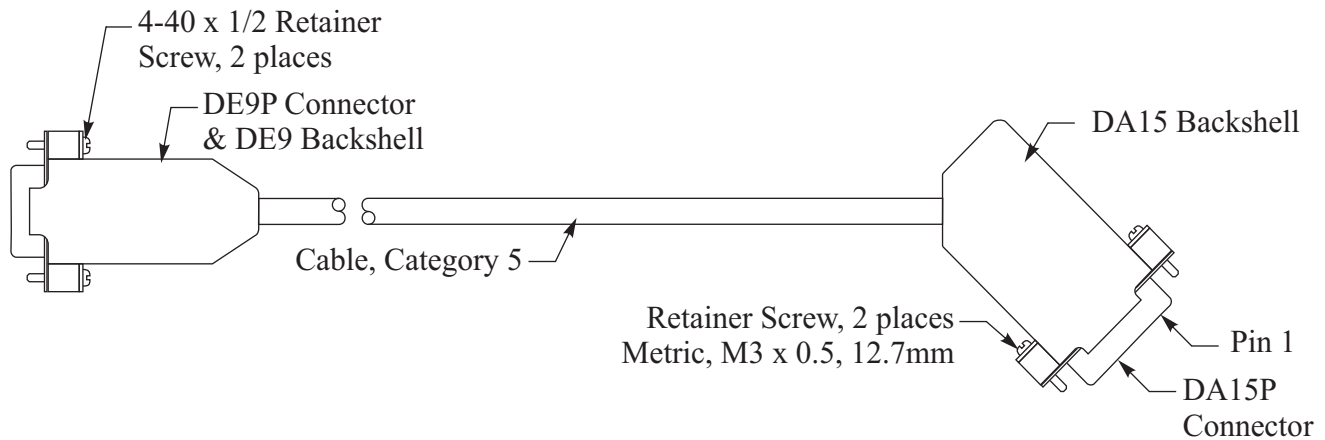

Notes:

- ① Shield wire must terminate to connector metal shell.