

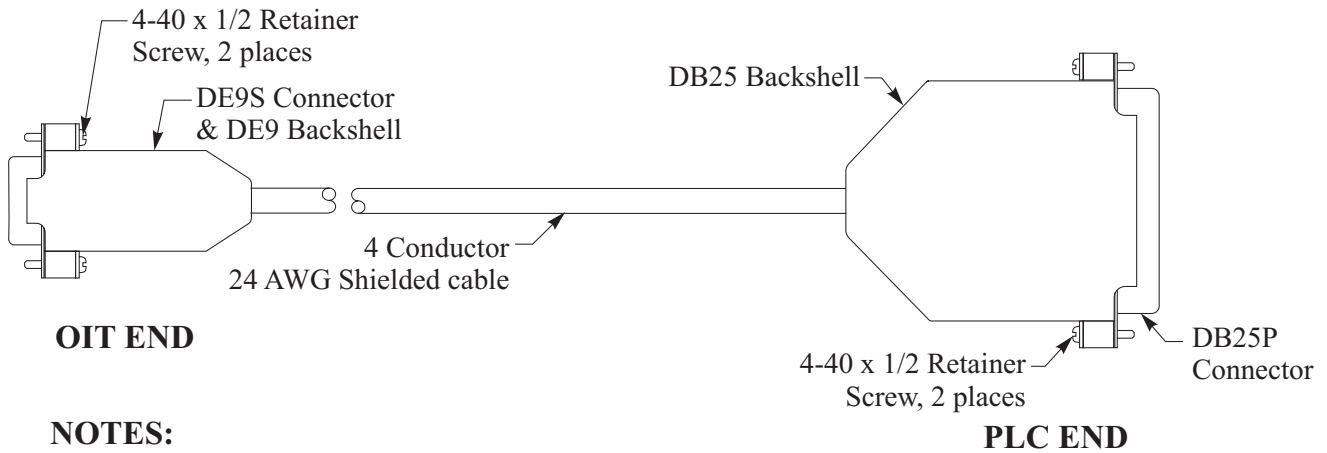

Controller Model: **GE Fanuc 90-30 CMM311 Port 2**
 Maple OIT Model: **Blue Series**
 Communication Type: **RS-232 with DB25 connector at PLC**

Use the wiring diagram and illustration to assemble a communication cable for use with a GE Fanuc 90-30 PLC (only for direct connection to CMM311 Port 2).



NOTES:

- 1 Install heatshrink on shield (bare wire) to avoid shorting to components.
- 2 Solder shield wire to the DE9S connector metal shell. Install heatshrink tubing over the shield wire to avoid shorting.

