

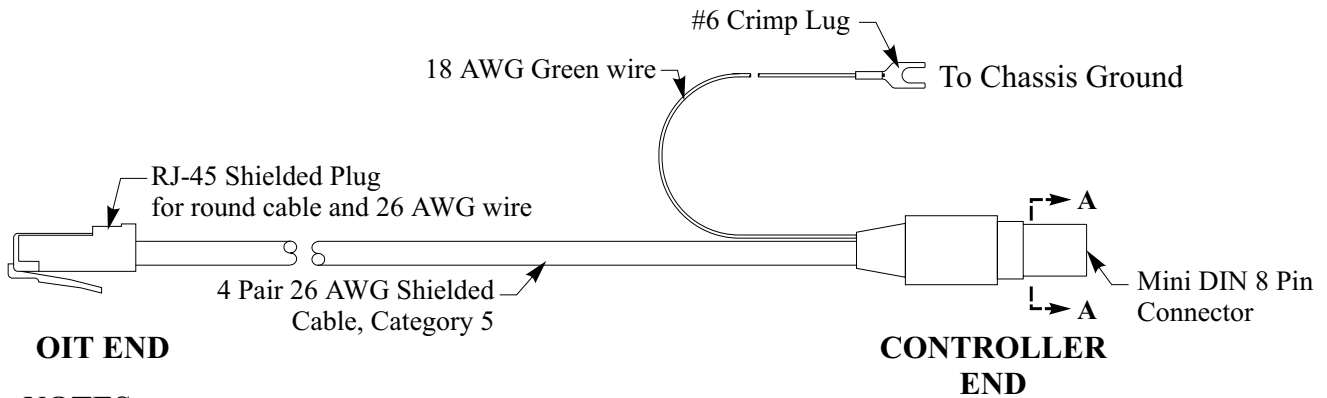

Controller Model: **Fife CDP-01**
 Maple OIT Model: **OIT3100 and OIT4100 Series**
 Communication Type: **RS-485 with Mini DIN 8 Pin connector at Controller**

Use the wiring diagram and illustration to assemble a communication cable for use with a Fife CDP-01 controller.



OIT END

CONTROLLER END

NOTES:

- 1 ➤ Twist together 18 AWG green wire and shield wire. Solder wires and insulate with heatshrink to avoid shorting.
- 2 ➤ Connect shield wire to the metal housing of the RJ-45 connector.

