



Controller Model: **Koyo DL205 (D2-250 CPU)**

Maple OIT Model: **OIT3100 and OIT4100 Series**

Communication Type: **RS-232 with 15 pin SVGA connector at PLC**

Use the wiring diagram and illustration to assemble a communication cable for use with a Koyo DL205 PLC (D2-250 CPU, Port 2).

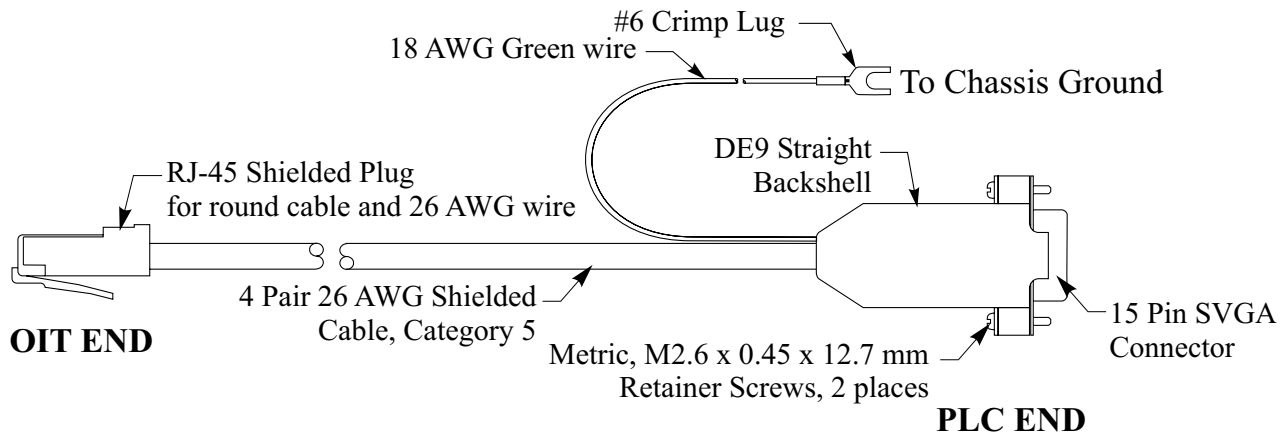

NOTES:

- 1 Twist together 18 AWG green wire and shield wire. Solder wires and insulate with heatshrink to avoid shorting.
- 2 Connect shield wire to the metal housing of the RJ-45 connector.

