

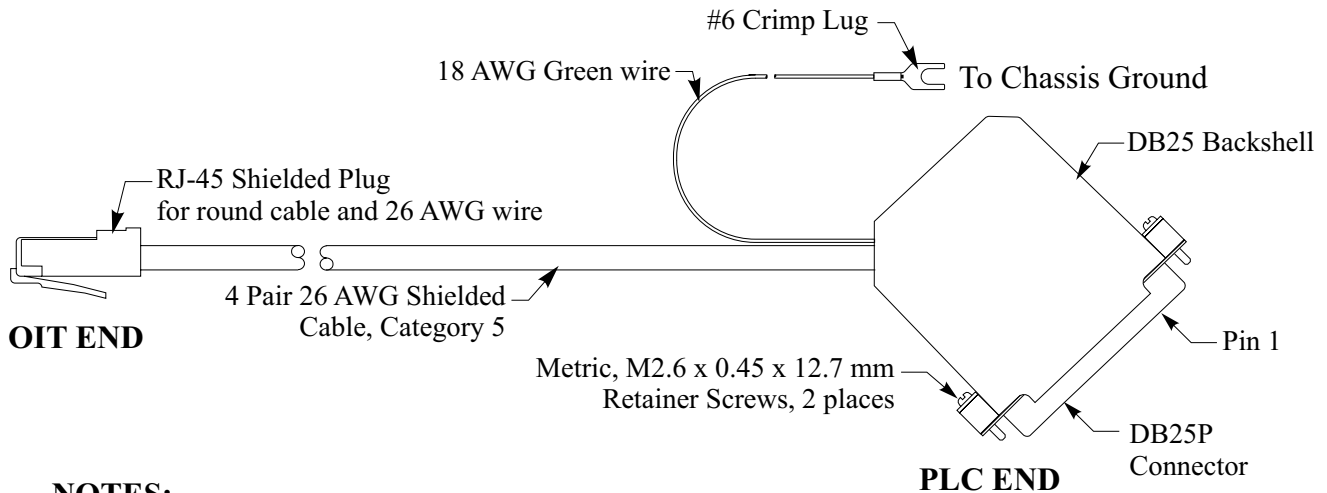

Controller Model: **Koyo DL405 Series**
 Maple OIT Model: **OIT3100 and OIT4100 Series**
 Communication Type: **RS-232 with DB25 connector at PLC**

Use the wiring diagram and illustration to assemble a communication cable for use with a Koyo DL405 PLC (D4-430 CPU, D4-440 CPU, or D4-450 CPU, Port 1).



NOTES:

- 1 Twist together 18 AWG green wire and shield wire. Solder wires and insulate with heatshrink to avoid shorting.
- 2 Connect shield wire to the metal housing of the RJ-45 connector.

