



Controller Model: **Idec MICRO³C and OpenNet Controller
Modicon TSX NANO (MODBUS)**

Maple OIT Model: **OIT3100 and OIT4100 Series**

Communication Type: **RS-485 with Leads at PLC**

Use the wiring diagram and illustration to assemble a communication cable for use with an Idec MICRO³ C, Idec OpenNet, or Modicon (Telemecanique) TSX NANO (MODBUS) PLC.

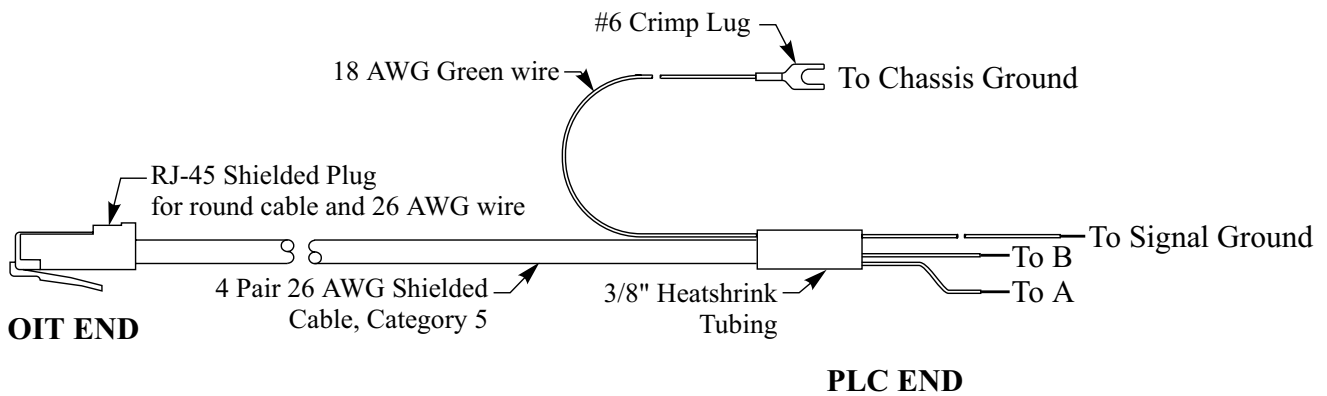

NOTES:

- ① Twist together 18 AWG green wire and shield wire. Solder wires and insulate with heatshrink to avoid shorting.
- ② Connect shield wire to the metal housing of the RJ-45 connector.

