



Controller Model: **GE Fanuc Series 90 and VersaMax**

Maple OIT Model: **OIT3100 and OIT4100 Series**

Communication Type: **RS-485 with DA15 connector at PLC**

Use the wiring diagram and illustration to assemble a communication cable for use with a GE Fanuc Series 90 or VersaMax PLC. This cable is for communication through a SNP Port connection.

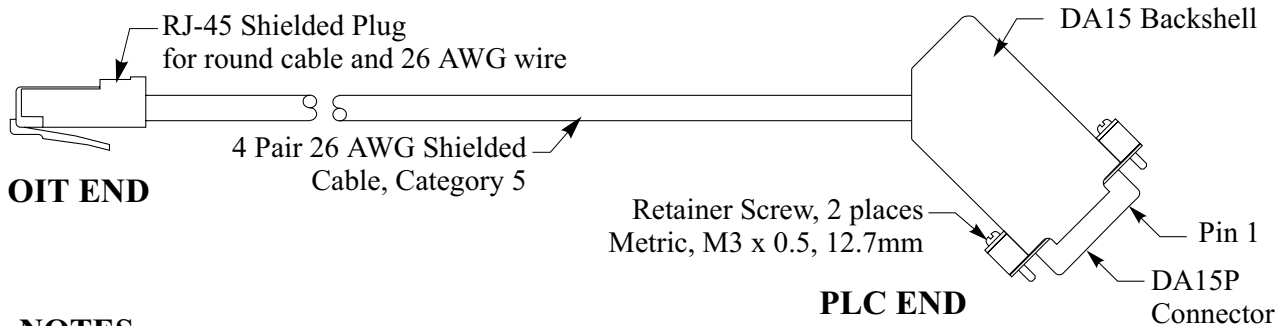

**NOTES:**

- 1 Install heatshrink on shield (bare wire) to avoid shorting.
- 2 Connect shield wire to the metal housing of the RJ-45 connector.

