



Controller Model: **Watlow Anafaze PPC 2000**

Maple OIT Model: **MAP460D, OIT3600B**

Communication Type: **RS-485 with RJ-12 at Controller**

Use the wiring diagram and illustration to assemble a communication cable for use with a Watlow Anafaze PPC 2000 controller.

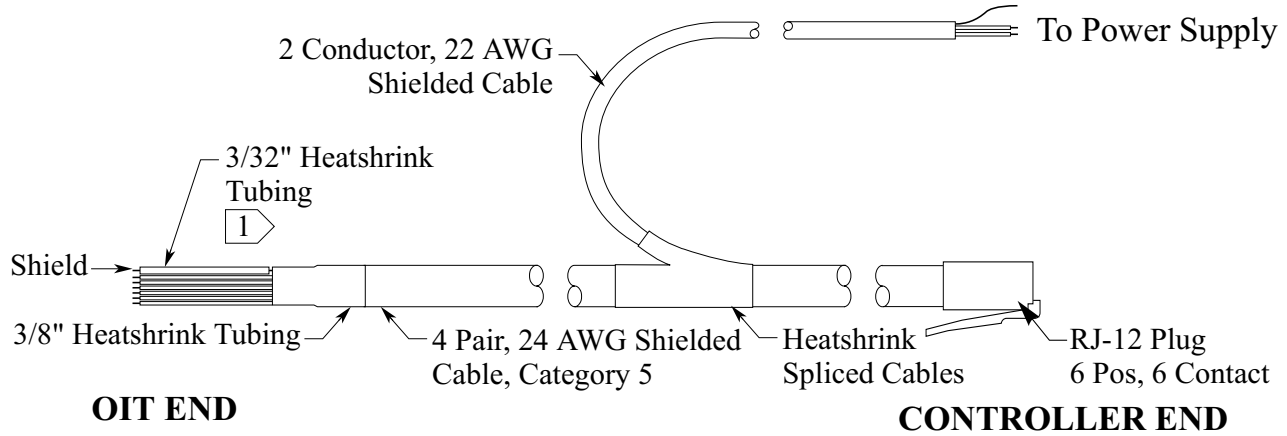

NOTES:

- 1 Install heatshrink on shield (bare wire) to avoid shorting to components.
- 2 Splice cables and shield. Heatshrink and seal connection.

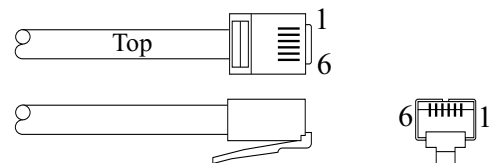
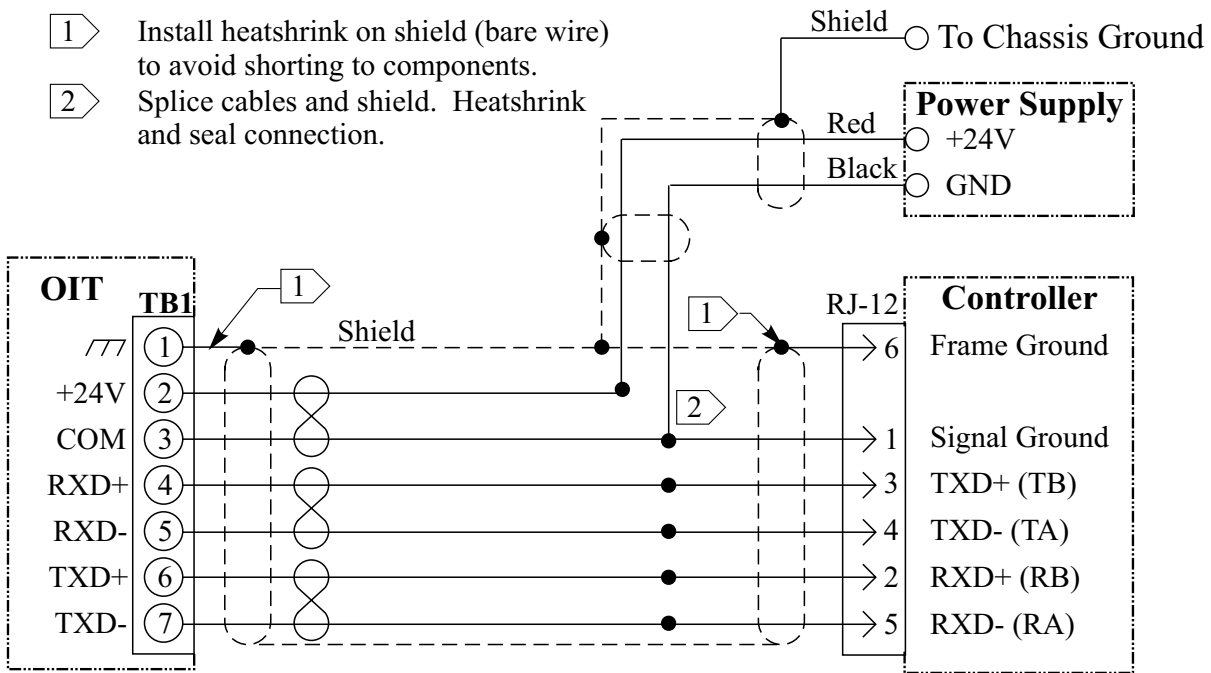

Pin Configuration
RJ-12 Plug