

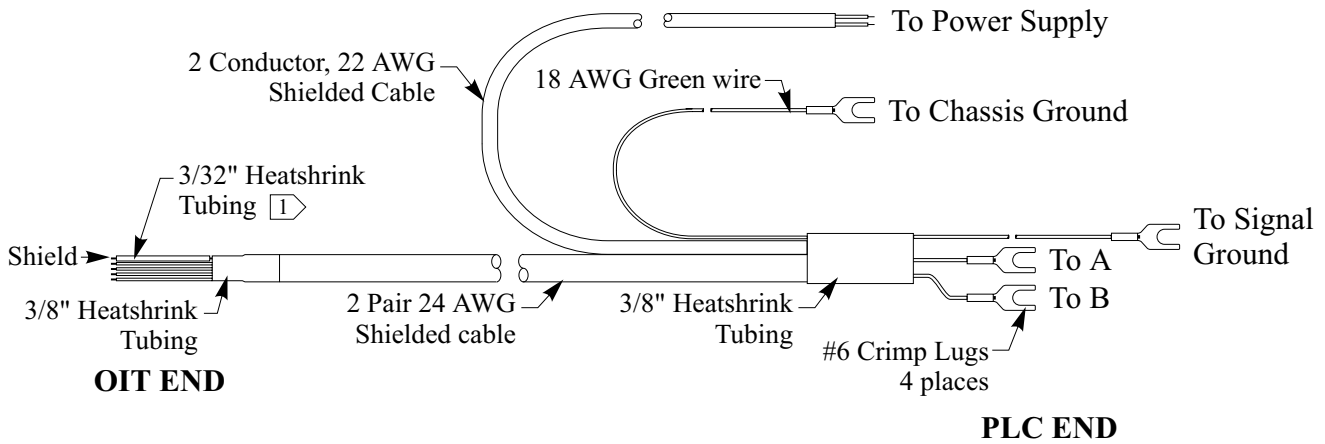

Controller Model: **Idec MICRO³C**
Modicon TSX NANO (MODBUS)
 Maple OIT Model: **MAP460D, OIT3600B**
 Communication Type: **RS-485 with Leads at PLC**

Use the wiring diagram and illustration to assemble a communication cable for use with an Idec MICRO³C or a Modicon (Telemecanique) TSX NANO (MODBUS) PLC.



NOTES:

- 1 Install heatshrink on shield (bare wire) to avoid shorting to components.
- 2 Twist together 18 AWG green wire and shield wire. Solder wires and insulate with heatshrink tubing to avoid shorting.

