



Controller Model: **Toshiba T1**

Maple OIT Model: **MAP460D, OIT3600B**

Communication Type: **RS-232 with Mini DIN 8 Pin connector at PLC**

Use the wiring diagram and illustration to assemble a communication cable for use with a Toshiba T1 PLC.

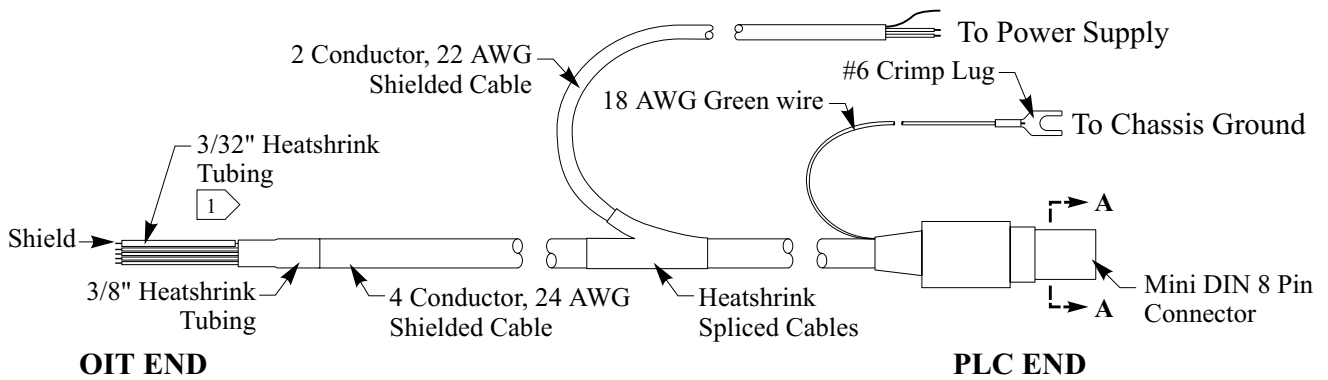

NOTES:

- 1 Install heatshrink on shield (bare wire) to avoid shorting to components.
- 2 Splice cables and shield. Heatshrink and seal connection.

